

Universal Load Cell



FEATURES

- Capacities: 50–5000 kg, 100–10k lbs.
- Fully-welded, stainless-steel construction
- Hermetically sealed, IP66 and IP68
- Certified to OIML R-60, 3000d
- Integrated overload stop (50–500 kg)
- Current calibration output (SC version) ensures easy and accurate parallel connection of multiple load cells
- **Optional**
 - FM Approved, ATEX and UKCA certified versions for use in potentially-explosive atmospheres



APPLICATIONS

- Hybrid scales
- Process weighing
- Belt checkweighers
- Dynamometers
- Material testing machines

The product is suitable for a wide range of hybrid scales, overhead track scales, belt scales, and process-weighing applications.

The fully-welded construction and water block cable entry ensure that this product can be used successfully in the demanding environments found in the food, chemical, and allied process industries.

DESCRIPTION

Model BSP is a stainless-steel S-type load cell that can be used in either tension or compression.

The product fully meets the stringent Weights and Measures requirements throughout Europe.

OUTLINE DIMENSIONS in millimeters

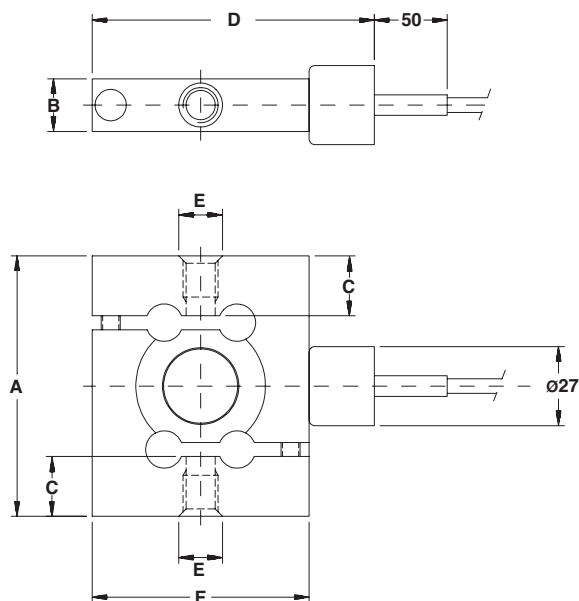

Cable specifications

Cable length: 10m

Excitation +	Green
Excitation -	Black
Output +	White
Output -	Red
Shield	Transparent

Cable screen is not connected to the load cell body. Performance may be affected if load cell cables are shortened. Tension applications result in a negative output signal.

Capacity (kg)	50, 125	250	500	1250	2500, 5000
A	84.3	88.9	88.9	95.2	120.6
B	23.9	18.0	18.0	24.1	36.6
C thread	12.7	14.0	14.0	14.0	29.2
D	85.7	84.1	96.8	84.1	84.1
E	M8x1.25		M12x1		M24x2
F	63.5	61.9	74.6	61.9	61.9

Capacity (lb)	100, 250	500	1k	2.5k	5k, 10k
A	3.32	3.50	3.50	3.75	4.75
F	2.48	2.44	2.94	2.44	2.44
B	0.94	0.71	0.71	0.95	1.44
D	3.36	3.32	3.81	3.31	3.31
E threads	3/8-24UNF-3B		1/2-20 UNF-3B		1-14 UNS-3B

Universal Load Cell

SPECIFICATIONS				
PARAMETER	VALUE			UNIT
Standard capacities (E _{max})	50, 125, 250, 500, 1250, 2500, 5000			kg
Standard capacities (E _{max})	100, 250, 500, 1000, 2500, 5000, 10000			lbs
Accuracy class according to OIML R-60 /NTEP	NTEP IIIIL	Non-Approved	C3	
Maximum number of verification intervals	10000		3000	
Minimum verification interval = V _{min} /E _{max} /Y				E _{max} /10000
Rated output (=S)	3 (2 for 2500 and 5000 kg)			mV/V
Rated output tolerance	0.03 (0.02 for 2500 and 5000 kg)			± mV/V
Zero balance	1.0			±% FSO
Combined error	0.0200	0.0500	0.0200	±% FSO
Non-repeatability	0.0100	0.0200	0.0100	±% FSO
Minimum dead load output return		0.0500	0.0167	±% FSO
Creep error (30 minutes)		0.0600	0.0245	±% FSO
Creep error (20–30 minutes)	0.0300	0.0200		±% FSO
Temp. effect on minimum dead load output	(0.0008)	0.0250	0.0070	±% FSO/5°C (°F)
Temperature effect on sensitivity	(0.0010)	0.0250	0.0050	±% FSO/5°C (°F)
Minimum dead load	0			% E _{max}
Maximum safe overload	150			% E _{max}
Ultimate overload	300			% E _{max}
Maximum safe side load	100			% E _{max}
Deflection at E _{max}	0.28 max.			mm
Excitation voltage	5 to 15			V
Maximum excitation voltage	18			V
Input resistance	350±3.5			Ω
Output resistance	350±3.5			Ω
Insulation resistance	≥5000			MΩ
Compensated temperature range	-10 to +40			°C
Operating temperature range	-40 to +80			°C
Storage temperature range	-40 to +90			°C
Element material (DIN)	Stainless steel 1.4542			
Sealing (DIN 40.050 / EN60.529)	IP66 and IP68			
SC-Version (current calibration)	Standard			

FSO—Full Scale Output

SC-version: The rated output and the output resistance are balanced in such a way that the output current is calibrated to within 0.05% of a reference value. This allows easy parallel connection of the load cells.

All specifications subject to change without notice.

CERTIFICATION MARKINGS

ATEX & UKEX Markings (For Zone 1, 2 and Zone 21, 22)

II 2 G Ex ib IIC T6...T4 Gb
 II 2 D Ex ib IIIC T70°C Db
 II 2 D Ex tb IIIC T70°C Db

II 3 G Ex ic IIC T6...T4 Gc or Ex nA IIC T6...T4 Gc
 II 3 D Ex ic IIIC T70°C Dc or Ex tc IIIC T70°C Dc

FM Approval Markings (USA and Canada)

IS Class I, II, III, Division 1, Groups A, B, C, D, E, F and G;
 NI Class I, Division 2, Groups A, B, C, and D;
 DIP Class II, III, Division 2, Groups F and G;
 T4;
 Ta = -25°C to +40°C;